

CNU 31

Retrofitting Retail Shopping Centers

Presented By
Monte Anderson



Charlotte
June 2, 2023



Demonstration Wall

(Old Minyards Wall Facing Wheatland - to be completed soon)

Other Work Started 4/25/22

Roof replacement on east building, repairs on west building.

Sewer replacement in a majority of the new spaces.

Removal of asbestos in most spaces.

Paint East Building.

Finish out 4 new spaces for new occupants, 7 more under construction.

Zoning Completed.



WHEATLAND PLAZA For Lease



402
1,750 ft²

406
1,000 ft²

407
396 ft²

408
396 ft²

410
1,120 ft²

414
6,198 ft²

418
10,000 ft²

331 ft² **422B** **422A** 857 ft²

426 1,488 ft²

280 ft² **428B** **428A** 600 ft²

275 ft² **430B** **430A** 838 ft²

438 1,400 ft²

442 1,375 ft²

446
800 ft²

450
1,455 ft²

454
1,845 ft²

456
1,800 ft²

466
2,000 ft²

502
502 ft²

510
3,585 ft²

518
1,805 ft²

526
4,000 ft²

530
1,200 ft²

532
991 ft²

533
318 ft²

535
1,831 ft²

550B
1,600 ft²

550C
1,165 ft²

550D
6,205 ft²

550A
1,165 ft²

550E
8,037 ft²

544
10,000 ft²

540B
5,902 ft²

540A
2,742 ft²

536
2,805 ft²

LOADING
DOCK AREA

Right sizing suites that are too deep

Before

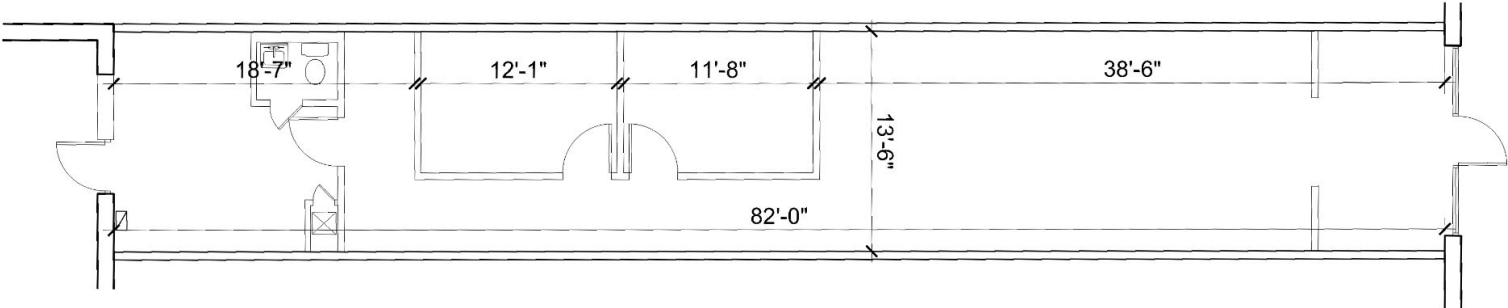

After

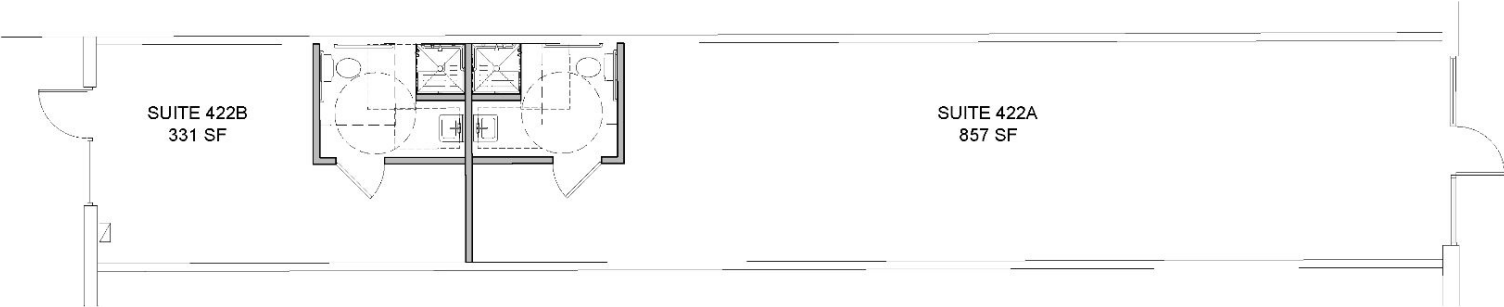

WHEATLAND

PLAY



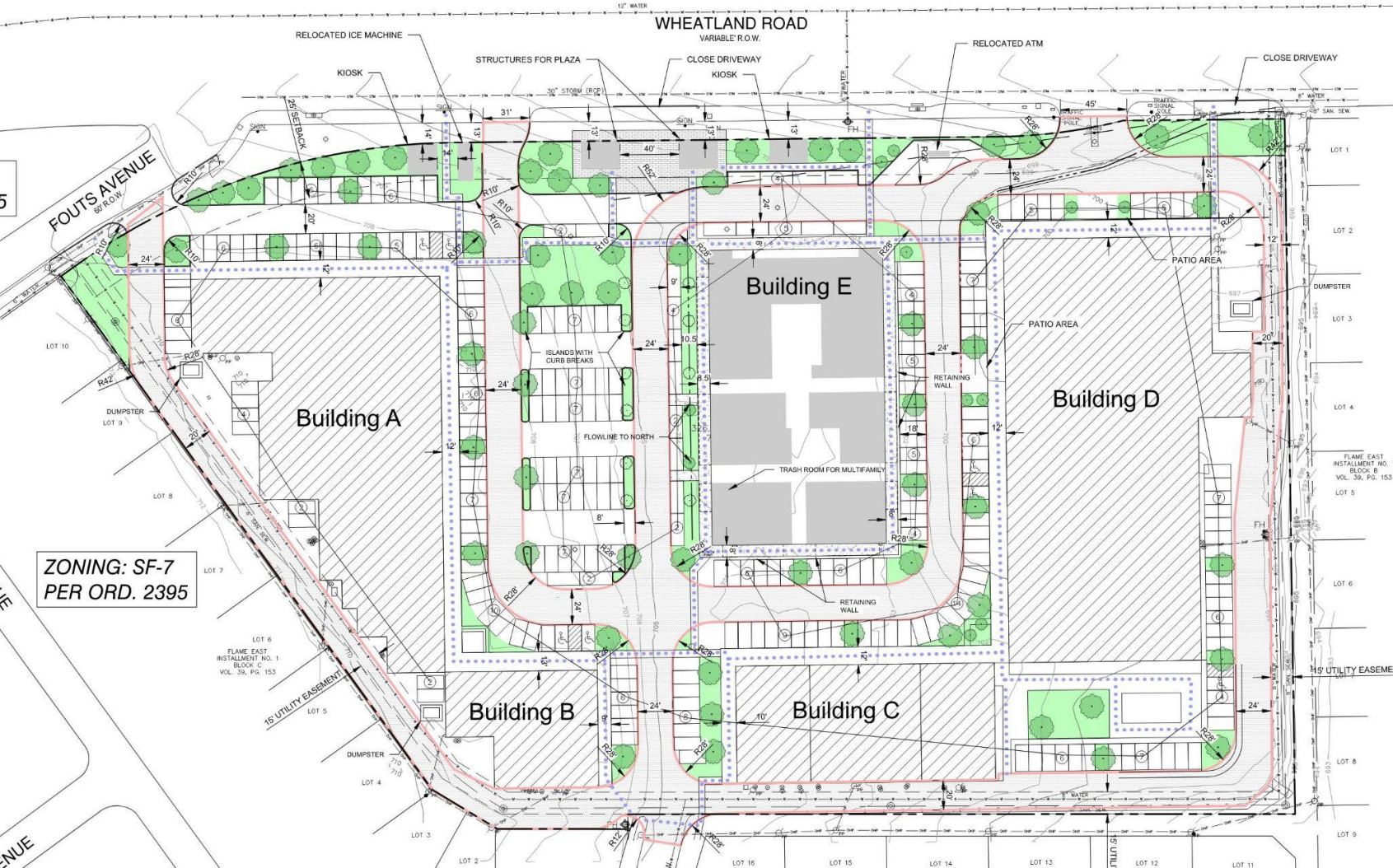

5

FOUTS AVENUE
80' R.O.W.

WHEATLAND ROAD
VARIABLE R.O.W.

ZONING: SF-7
PER ORD. 2395

Building A

Building E

Building D

Building B

Building C

LOT 1
LOT 2
LOT 3
LOT 4
LOT 5
LOT 6
LOT 7
LOT 8
LOT 9
LOT 10
LOT 11
LOT 12
LOT 13
LOT 14
LOT 15
LOT 16

FLAME EAST
INSTALLMENT NO. 1
BLOCK E
VOL. 39, PG. 153

15' UTILITY EASEMENT









Boutique Motel

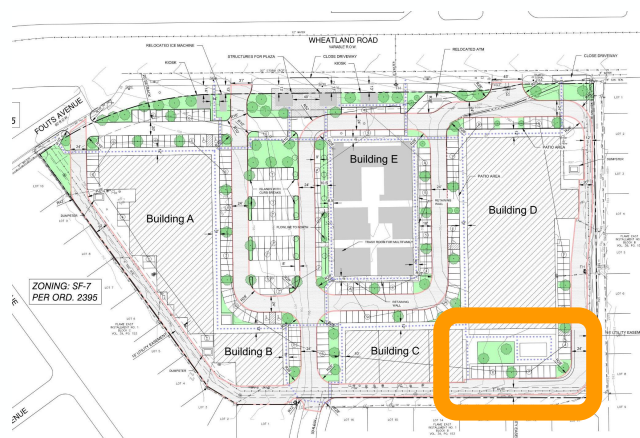

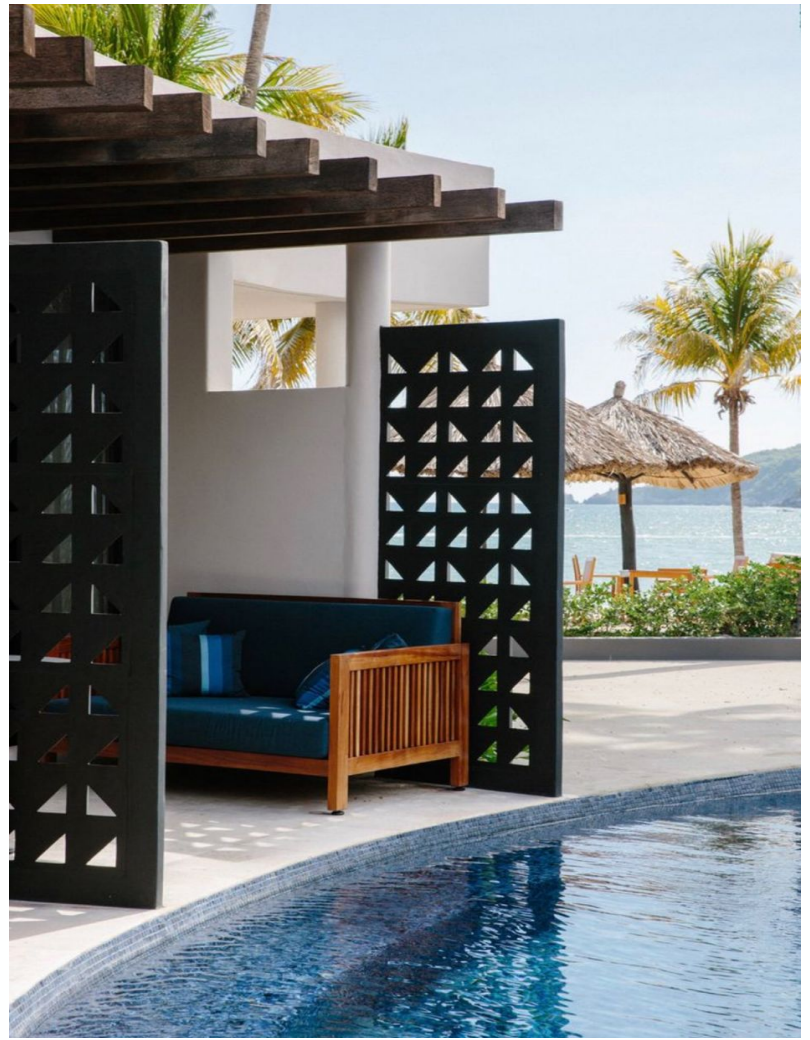

WHEATLAND RD. PROPOSED CROSS SECTION

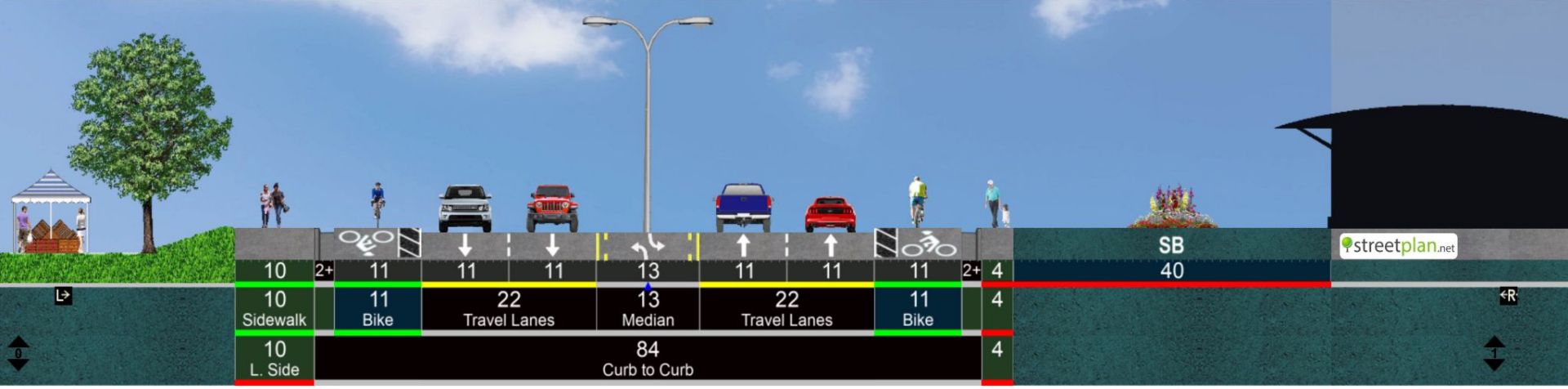



SHOP
EAT
WORK
PLAY

MARKET
PLACE

DeSoto

Allstate
Way Sion
EVENTS

Mr Jim's. Pizza
972-223-2161

XIN'S GARDEN
DeSoto Cleaners
BRAIDS
WESTLAKE DONUTS
Easy NAILS

OVERFLOWING LIFE
MINISTRIES
DESOTO FLORIST
ALBRA DEWYN
EMPORIUM
Watch & Jewelry
REPAIR

Parking to Plaza

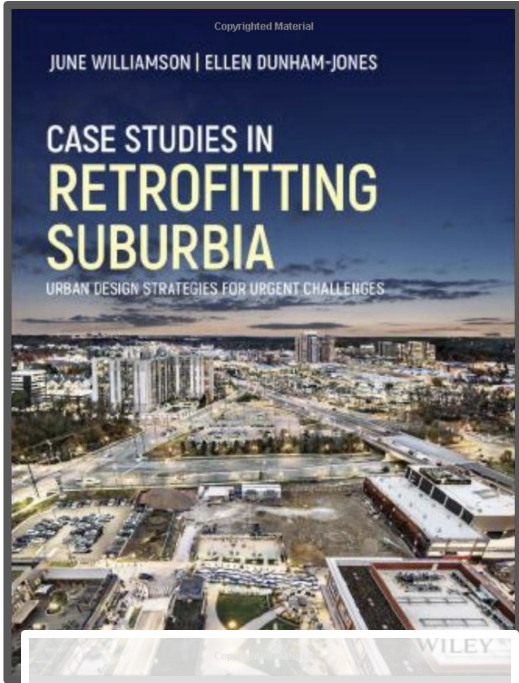

Retrofitting Suburbia

CNU Website Front Page

CNU 31 Charlotte: May 31 – June 3, 2025
CNU is thrilled to bring our 31st annual Congress to one of the most diverse, vibrant cities in the American Southeast with deep roots in new urbanism – the Queen City of Charlotte, North Carolina.

[LEARN MORE](#) [REGISTER NOW!](#)

Building Places People Love.

-
-
-
-

CHARTER AWARDS 2022

BECOME A MEMBER

BUILDING LOCAL STRENGTH

GET CNU-ACCREDITED!

CNU 29 PLENARY: DESIGNING FOR JUSTICE

1900 2000

1900-1910
1910-1920
1920-1930
1930-1940
1940-1950
1950-1960
1960-1970
1970-1980
1980-1990
1990-2000

(We all have these)



Strip mall style tenants

Former grocery store, then hardware store

Grow DeSoto Market Place

BELT LINE ROAD

89°02'47" E 430.00' PLAT
S 89°03'30" E 430.00' PLAT

99 Cent Store as anchor tenant?

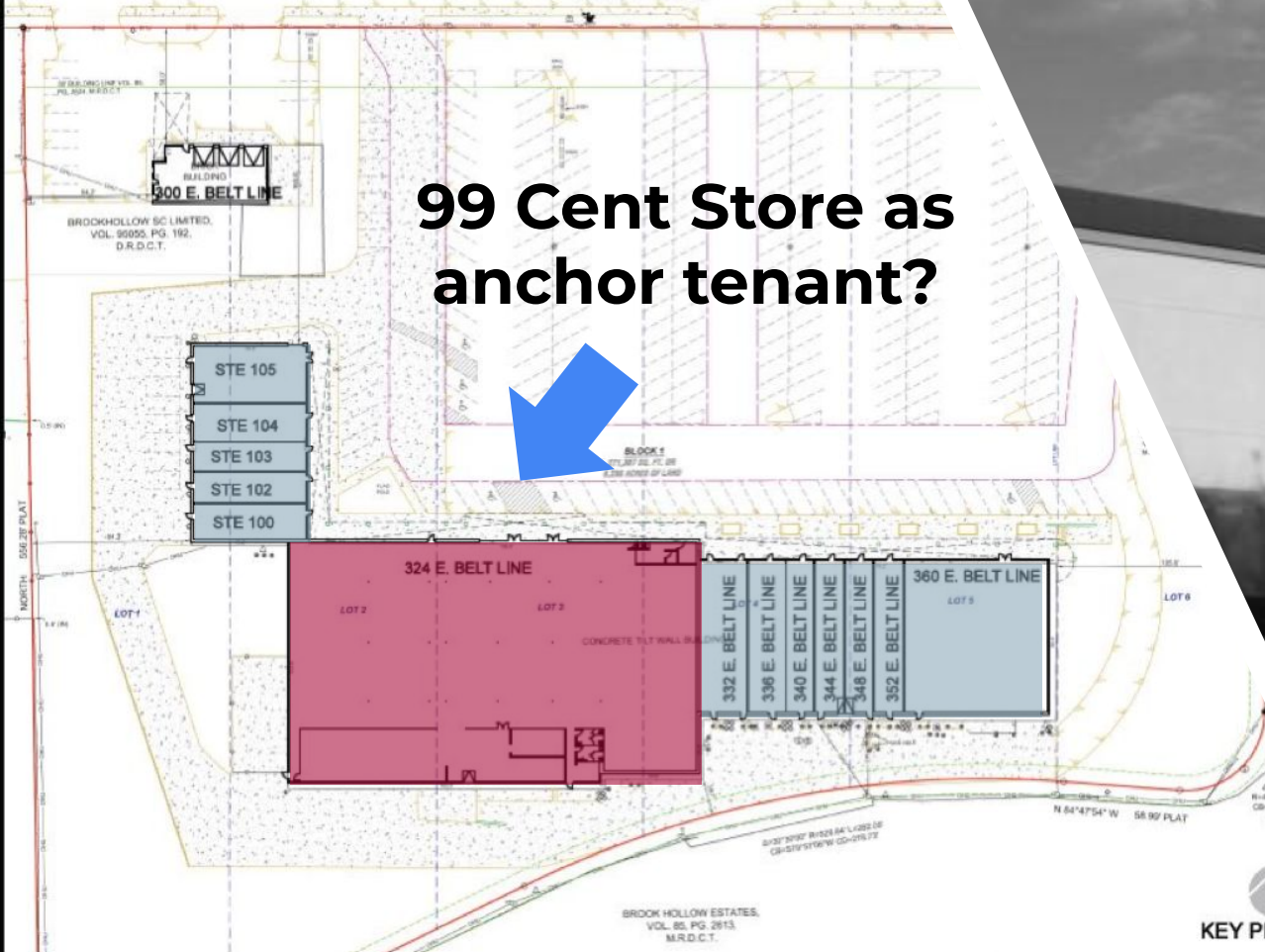

BROOK HOLLOW ESTATES,
VOL. 85, PG. 2813,
M.R.D.C.T.





- 14 6"x6" POSTS 13' HT. W/ STRING LIGHTS & PERENNIAL PLANTS @ 2' INTERVALS / 12" DIA. SPAC.
- NATIVE TX WILDFLOWERS: SCROONIA FRONT SIDEWALK MURALS

- NEW LIVE OAK TREE 10' TO 6" CAL.
- STREETSIDE OVERFLOW DECK - CONTACT TO EXISTING G (8" HIGH SIDE WALK & PAV. CEMENT/PAV)
- RAIN GARDENS BY NATIVE GRASSES (FLOOD PLANS) TO BE CEMENTING, REMOVING EX. CONCRETE PAVEMENT
- NEW PLANTED BEDS (MISC) CONC. PAVEMENT

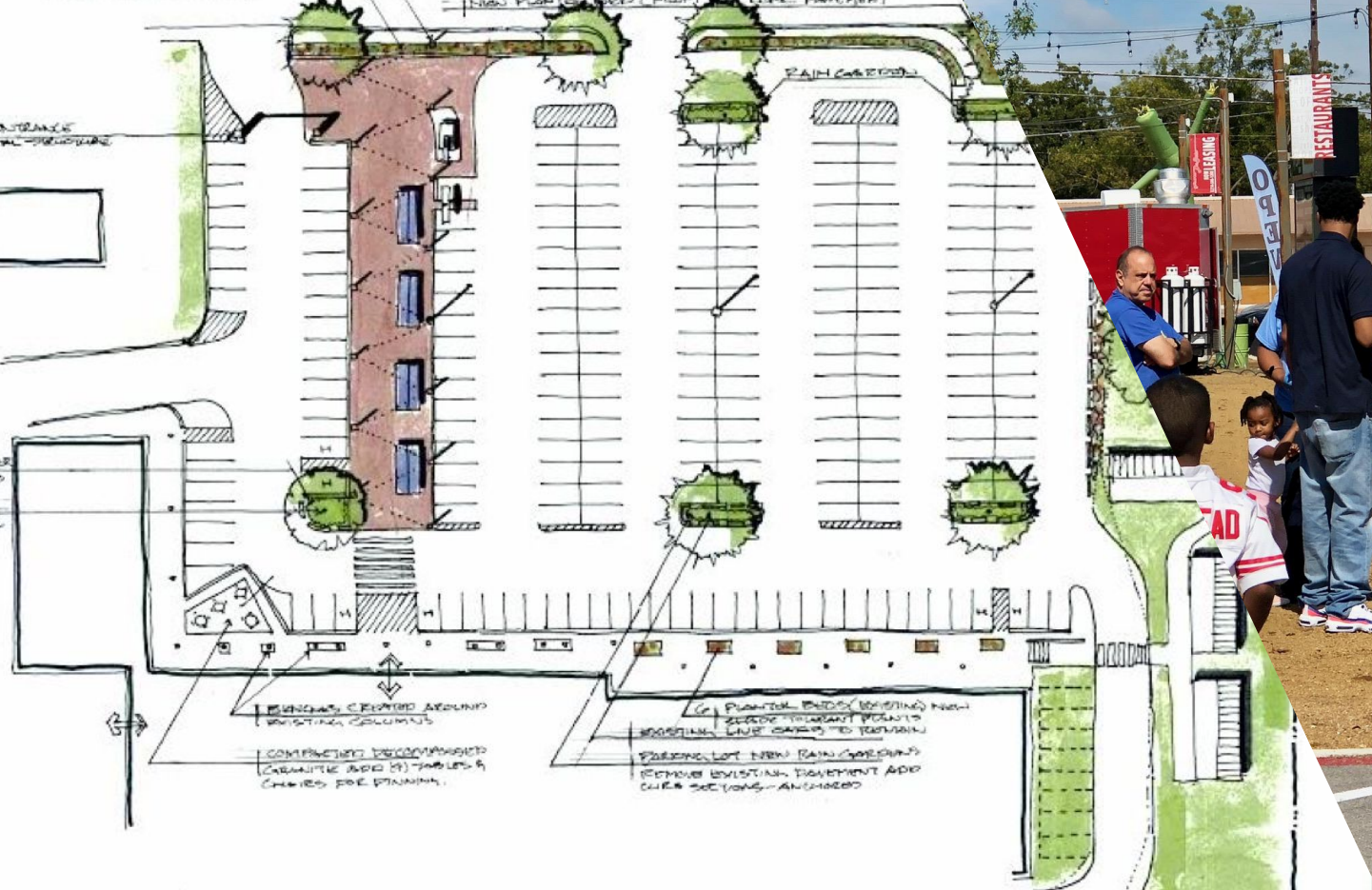



200
769RSF

201
777RSF

202
649RSF

203
649RSF

204
804RSF

205
597RSF

206
612RSF

300
725RSF

400
226RSF

401
199RSF

402
264RSF

403
350RSF

404
195RSF

405
185RSF

406
185RSF

407
185RSF

408
195RSF

500
1,736RSF

600
512RSF

601
522RSF

602
486RSF

603
486RSF

604
405RSF

605
410RSF

614
171RSF

613
171RSF

612
171RSF

611
476RSF

610
472RSF

609
483RSF

606
743RSF

608
203RSF

607
174RSF

700
491RSF

701
514RSF

702
464RSF

703
171RSF

704
171RSF

705
174RSF

706
541RSF

707
541RSF

422
389RSF

421
236RSF

STORAGE

420
CONFERENCE

419
485RSF

800
3,496RSF

900
1,521RSF

415
536RSF

414
526RSF

413
557RSF

7 Starter Kitchens

400sf

\$1500 / month

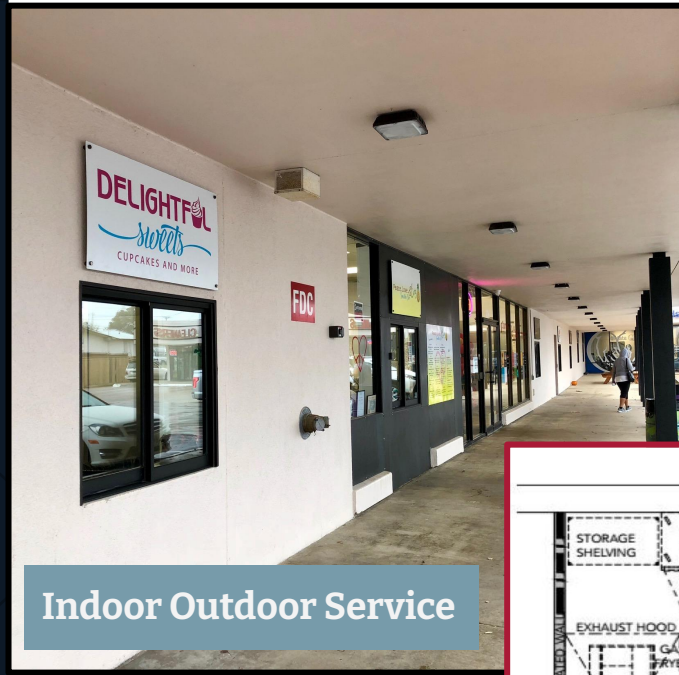

Indoor Outdoor Service

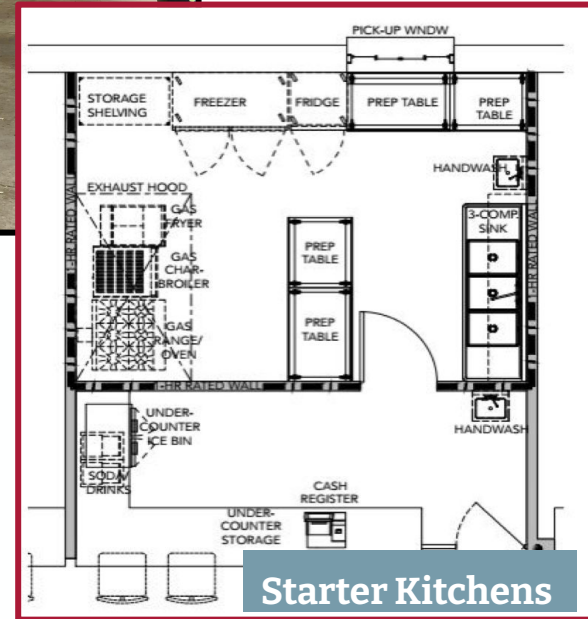

Starter Kitchens



Community coaching





Bring activity making on site







Affordable Office Space \$250-\$525



Creating Mixed Use Grow DeSoto Marketplace



One Story, no pressure on parking
Grow DeSoto Marketplace



Problem Solving for the unhoused Golden Triangle



PENTAGON PARKWAY

MARVIN D. LOVE FREEWAY
US HIGHWAY NO. 67

S POLK STREET





S POLK STREET

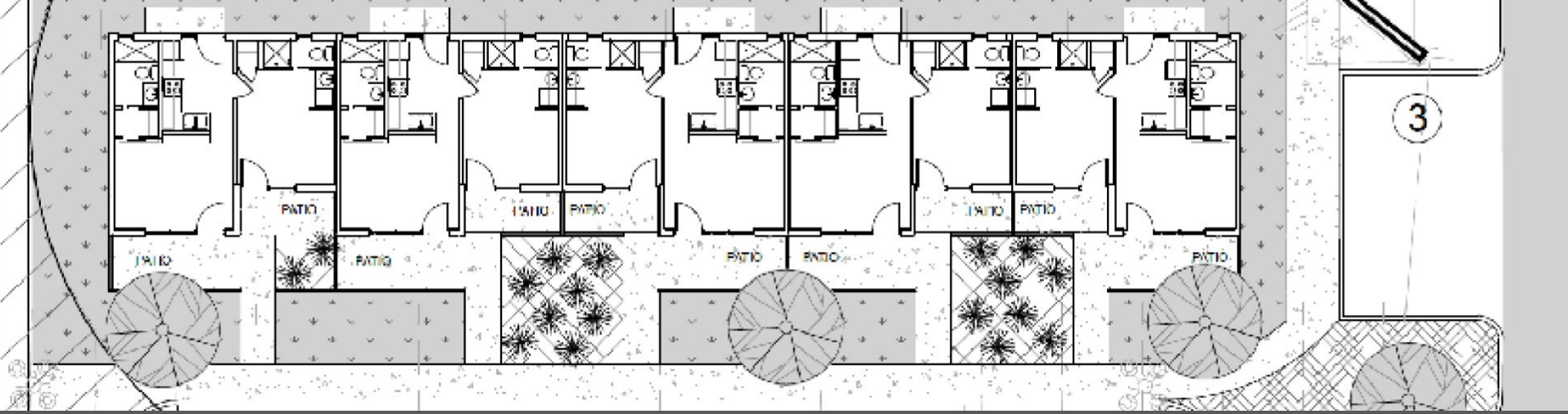

Respect Golden Triangle



Conceptual Rendering / Finished Product



Conceptual Rendering / Finished Product



Conceptual Rendering / Finished Product

